

**Product info sheet  
Room humidistat****Hygroswitch  
Hygroswitch-i****Type Survey**

Type	Product No.	Type of contact
Hygroswitch	4204201K	changeover contact: max. 5 A , with adjusting knob
Hygroswitch-i	4204201L	changeover contact: max. 5 A, with internal scale
Hygroswitch	4204701K	changeover contact (gold plated): 1...100 mA
Hygroswitch-i	4204701L	changeover contact (gold plated): 1...100 mA, with internal scale

**Technical Data**

measuring element ..... Polyga®-measuring element, water resistant

control range ..... 40 ... 90 %RH

lifetime ..... &gt; 6.000 breaking cycles

**microswitch with silver contact**

max. breaking capacity

ohmic load, dehumidifying ..... 5 A 250 V AC

ohmic load, humidifying ..... 2 A 250 V AC

inductive load (power factor &gt;0.8) ..... 1 A 250 V AC

min. switching current ..... 100 mA<sup>1)</sup>**microswitch with gold contact**

max. breaking capacity ..... 100 mA 250 V AC

min. switching current ..... 1 mA<sup>1)</sup><sup>1)</sup> not relevant when switching high resistance loads (>10kOhm) e.g. logic levels**Please observe the notes on voltage.**

allowable operating temperature ..... 0 ... 60 °C

allowable storage temperature ..... - 40 ... 60 °C

air-speed ..... 0.2 ... 8 m/s

installation altitude ..... ≤ 4.000 m above sea level

influence of temperature

ref. to 23 °C ..... ≤ ± 0.2 %RH/K

typ. response time  $t_{50}$  at v = 2 m/s ..... 1.2 min

electrical contacting ..... connecting terminals

**applied directives / standards**

low-voltage directive 2014/35/EU

EMC directive 2014/30/EU

DIN EN 60730-1:2012-10      DIN EN 60730-2-13:2018-09

action ..... 1.C.L

rated impulse voltage ..... 4 kV

ball indentation test for temperature ..... 92 °C

protective system ..... IP30D

degree of pollution ..... 2

dimensions ..... approx. 81x81x28 mm

independently mounted sensing control

installation ..... wall mounting

weight ..... approx. 58 g

**Opening the housing**

Apply a flat-headed screwdriver at the top in the locking slot and press inwards until the housing springs open.

**Description of the hygostat**

The humidity measuring element which is manufactured by Galltec under the name Polyga®, consists of several plastic fabric bands each with 90 individual fibres with a diameter of 3 µm each. The fibres are provided with hygroscopic characteristics by a special process. The measuring element adsorbs and desorbs moisture. The effect, swelling predominantly in longitudinal direction, is transmitted via a lever system to a microswitch with a small switching distance. The measuring element responds to the change in air humidity. It is possible to adjust the lever system by setting the adjustment knob so that the microswitch is actuated when the set air humidity is reached.

The fan shaped measuring element is accommodated inside the housing and must be protected against coarse dust, dirt and water. The humidistats are designed for pressureless systems. The installation location must be selected so that condensed water cannot enter the inside of the housing. The installation position preferably with ventilation slots at right-angles to wind direction.

**Application**

The room humidistat **Hygroswitch** is an on-off controller to control the relative air humidity. It is used to control air humidifying and dehumidifying in offices and computer rooms. Other areas of use are storage of foodstuffs and luxury foods, cooling rooms for fruit and vegetables, greenhouses for gardening use, the textile industry, the paper and printing industry, the film industry and hospitals

In the case of the room humidistat **Hygroswitch-i** the external adjustment knob is replaced with an adjustment wheel with a scale inside the housing. The adjustment wheel needs to be aligned to the red mark.

**Notes on voltage**

*The measurement location of the humidity controller should be selected such that there is no build-up of condensate on or in the device. There is a risk of voltage arcing in the event of water condensation on the microswitch or connecting terminals which might destroy the controller. Particularly operating with a voltage higher than 48V may endanger people. The humidity controller should be used up to a maximum of 95 %RH.*

**Connection diagram**

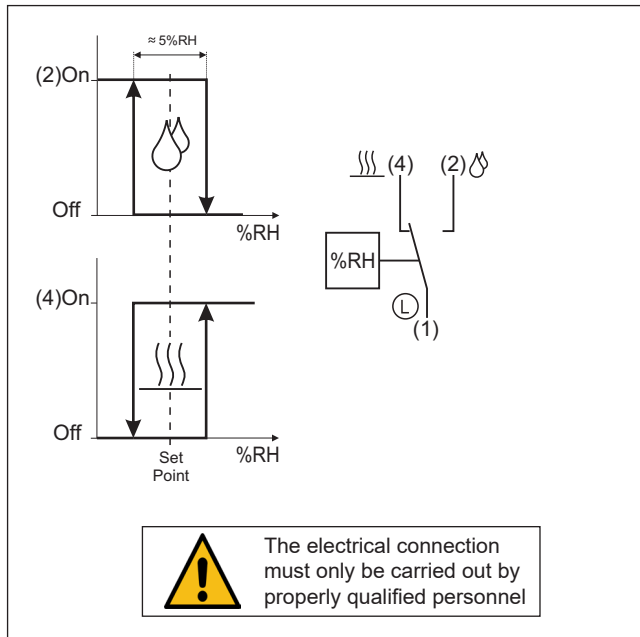

**Dimensions diagram**

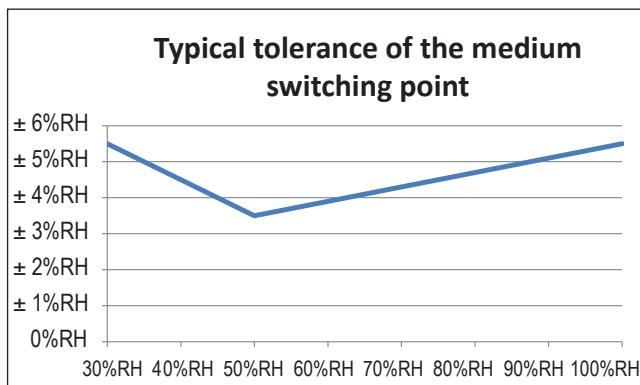
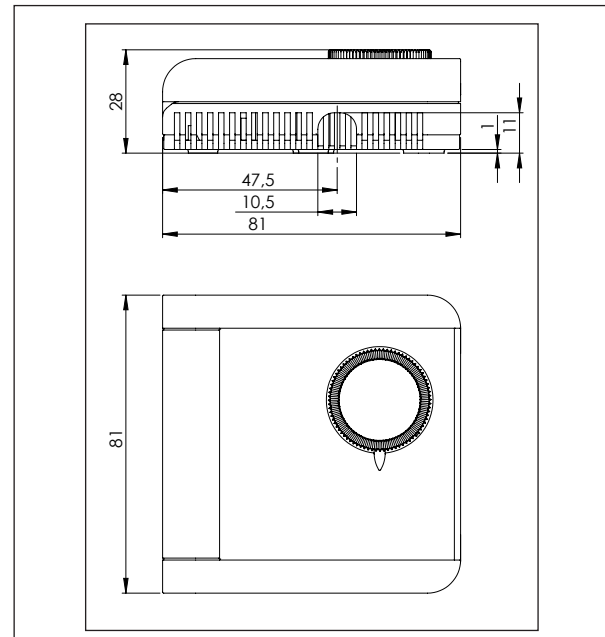

1-point-adjustment at 48 %RH/23 °C  
 Long-term drift: ≤ ± 1 %RH p.a.

**Typical switching differential with typical tolerance**

Setpoint value humidity	Switching differential	Tolerance
50 %RH	5 %RH	± 1,5 %RH
60 %RH	4 %RH	± 1,5 %RH
70 %RH	4 %RH	± 1,5 %RH
80 %RH	3 %RH	± 1 %RH
90 %RH	3 %RH	± 1 %RH

**Physical influence of temperature on the relative air humidity**

at a temperature fluctuation of ±1 °C referred to various room temperatures.

	10 °C	20 °C	30 °C	50 °C
10 %RH	± 0,7 %RH	± 0,6 %RH	± 0,6 %RH	± 0,5 %RH
50 %RH	± 3,5 %RH	± 3,2 %RH	± 3,0 %RH	± 2,6 %RH
90 %RH	± 6,3 %RH	± 5,7 %RH	± 5,4 %RH	± 4,6 %RH

It is thus of extreme importance that the temperature is constant for measurements of the relative air humidity. The air must be homogenous.

**Mounting**

has to be carried out by properly qualified personnel

- The humidistat must not come into direct contact with water, e.g. splashed water when cleaning the climatic chamber etc.
- The mounting location should be chosen so that a representative measurement of the air humidity can be guaranteed, i.e. the humidity readings at the mounting location should correspond to those in the room as far as possible.
- The humidistat should be exposed to the flow of air.
- When mounting the humidistat on a patress, avoid external air getting onto the humidity measuring element of the humidistat by sealing it appropriately.

**Cleaning instruction**

1. Disconnect the device from the power supply
2. Remove the cover. Clean the cord shaped measuring element using a soft brush and clean water. Do not use a detergent as it cannot be dispersed.

**It is important that no water is allowed to get onto the other components, particularly microswitches, terminals or printed circuit boards.**

2. Air drying. Do not use warm or hot air (hair dryer).

**Maintenance**

The measuring element is maintenance-free in pure ambient air. Aggressive media containing solvent can cause measuring errors depending on the type and concentration. Deposits which eventually form a water-repellent film over the measuring element are harmful (such as resin aerosols, lacquer aerosols, smoke deposits etc.).

**Contact with the inner parts of the humidistat nullifies the warranty.**